

.SCI saccap coyard icarus
NIGERIA LTD.

COMPANY GENERAL PRESENTATION

Company profile

Head-office : Lagos - Nigeria 

Established : 2014



SCI Nigeria Ltd - Lagos

Tel: 081-688 66 016
21, Boyle Street (2nd Floor)
Onikan - Lagos

SCI Nigeria Ltd - PH

Tel: 070-460 82 992
32, Emekuku Street
Port Harcourt

European offices

Saccap

112, Avenue de Vendôme
41034 Blois
France



Coyard

1, Rue de la Nouette
49072 Beaucouzé Cedex
France



Icarus

Rue des Alouettes, 100
4040 Herstal
Belgique



Markets

- Oil & Gas
- Chemical & Petrochemical
- Energy sector
- Aerospace
- ...



Customers

- End users (i.e. oil companies)
- EPC (Engineering Procurement Construction)
- Process Equipment Manufacturers
- ...

Activities

Manufacturing of flanges, specialty forgings and valves.
Major single source supplier of **complete piping solutions**.



Subsea forged pieces



Valves



Compact flanges



Piping product

References



PIPING & FITTINGS

Scope of supply

Flanges

- Compact flanges
- Standard flanges
- Long welding neck
- Orifice
- Anchor
- Swivel
- Fully designed & calculated flanges

Pipes

Seamless & Welded

Dimensions:
1/2" → 60"
In all Wall thicknesses

Forged Fittings

- Elbows
- Tees
- Caps
- Coupling
- Plugs
- Nipples
- Crosses
- O-lets

BW Fittings

- Elbows
- Tees
- Lateral & Barred Tees
- Reducers
- Caps
- Crosses

Boltings

- Bolts
- Nuts
- Washers
- Screws
- Studs

Gaskets

- API ring joints
- Anti vibration
- Elastomer seals
- Engineering plastics
- Expansion joints
- O-rings
- Hydraulic seals
- Spiral wound gaskets

Clamps & Hubs

- Clamps connectors
- Hubs
- API Clamps

Material grades

Stainless steel Corrosion resistance

- 316 Mo+
- 317L
- Alloy 28
- Alloy 20
- 904L
- 19.25 HMo
- 254 SMO®

Alloy and stainless steel High temperature

- P11
- P22
- P5
- P9, P91
- 304 H
- 321 H
- 347 H
- 800, 800 H, 800 HT

Austenitic-ferritic steel

Duplex : UNS S31803 / S32205
Super Duplex :
UNS S 32750 / S32760

Nickel and Nickel alloy

Alloy 600, 601, 625, 825
C276

Carbon steel

- A106 Gr B
- A105
- A234WPB
- P265 GH

Low temperature :

- LF2, A333 Gr 6
- LF3, A333 Gr 3

High Yield :

API 5L X52-60-65-80

... this is a non-exhaustive list, Do not hesitate to contact us for other needs.

PDF version available for download at www.sci-ng.com

Piping material

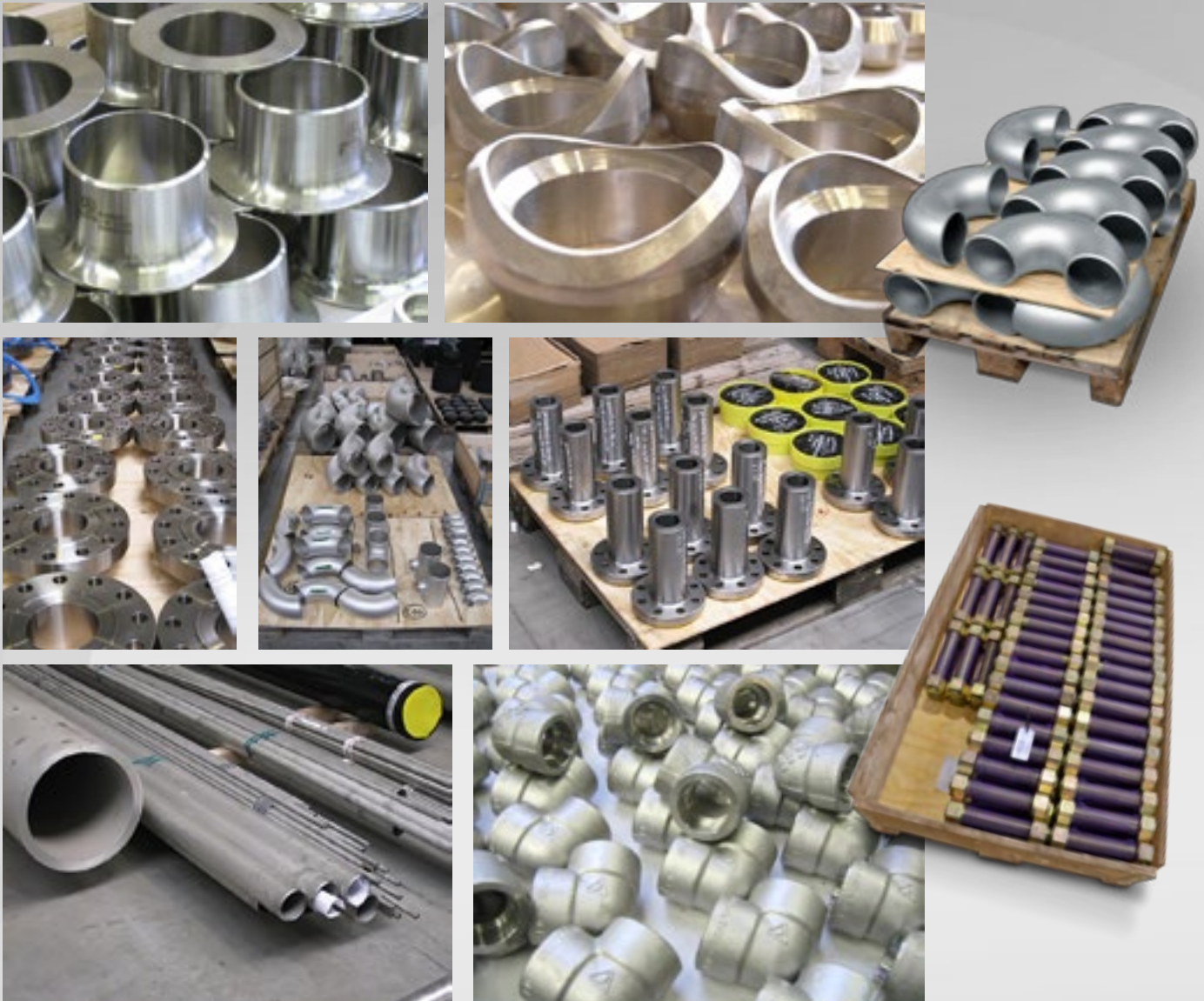

Extruded Manifolds
Material : Alloy 800 HT
Client : Total Petrochemicals Gonfreville



Extruded Manifolds
Material : Alloy 800 HT
Client : Total Petrochemicals Gonfreville

VALVES

Product range

	150lbs	300lbs	600lbs	900lbs	1500lbs	2500lbs
ON/OFF BALL VALVES						
Floating Ball	2" - 10"	½" - 8"	½" - 6"	½" - 4"	½" - 2"	½" - 1"
Trunnion Ball	2" - 24"	2" - 24"	2" - 24"	2" - 24"	1" - 24"	1" - 24"
Double block & Bleed ball						
ON/OFF BALL VALVES						
Trunnion Ball	6" - 24"	6" - 24"	6" - 24"	6" - 24"	6" - 24"	6" - 24"
Double block & Bleed ball						
THROUGH CONDUIT GATE						
Slab Gate	2" - 24"	2" - 24"	2" - 24"	2" - 24"	1" - 24"	1" - 24"
DUO CHECK						
Dual plated Wafer Check	2" - 24"	2" - 24"	2" - 24"	2" - 20"	2" - 20"	2" - 18"
CASTING ≥2"						
Gate	2" - 24"	2" - 18"	2" - 14"	2" - 10"	2" - 10"	2" - 8"
Globe		2" - 14"	2" - 10"	2" - 8"	2" - 4"	2" - 4"
Check (Swing, Piston and Ball)						
FORGINGS ≤2"						
Gate	½" - 2"					
Globe						
Check (Swing, Piston and Ball)						

SPECIAL ITEMS

Navy - Military - Nuclear - Cryogenic - Oxygen Service - 3-Way Ball - Top Entry Ball - Fully Welded - Wafer Swing Check - Bellow sealed - ...
Actuated as per request

Sizes	from ½" to 24" (> 24" upon request)
Pressure Ratings	CL-150 to 2500 – PN 16 to PN 400 – API 6a : 3.000 / 5.000 / 10.000
Material	Main : Carbon Steel (with cladding) / Stainless Steel / Duplex / Nickel Alloys Others : Cupro Aluminium / Titanium / ...

EUROPEAN ORIGIN
TOP QUALITY MATERIAL SOURCING
ASTM – PED – NORSOK M630 – CUSTOMER SPECIFICATION

Fast-track tailor made valve solutions

- Manufacture speciality valves in small and medium sized lots
- Machine out of forged bar, blocks or pre-formed forgings
- Supply difficult to source material grades with short delivery lead times

Strengths

- Short lead times
- Valves for use under extreme service conditions:
 - Corrosive products
 - Abrasive products
 - High pressure
 - High and low temperatures
- Tailor-made solutions



Through Conduit Gate 8" 2500#
Hubbed ends Duplex
 Client : Petrofac



Trunnion Mounted Ball Valve
2 1/16" API 5000 RTJ Alloy 625
 Client : McDermott



Wafer Duo-Check
10" 2500# Alloy 625



Trunnion Mounted Ball Valve
20" 1500# Carbon Steel
 Client : Total Qatar



Trunnion Mounted Ball Valve
2.1/16" API 5000 - Inconel 625 Body
Flanged ends, RTJ type 6B
 Engineering : Hyundai Heavy Industries

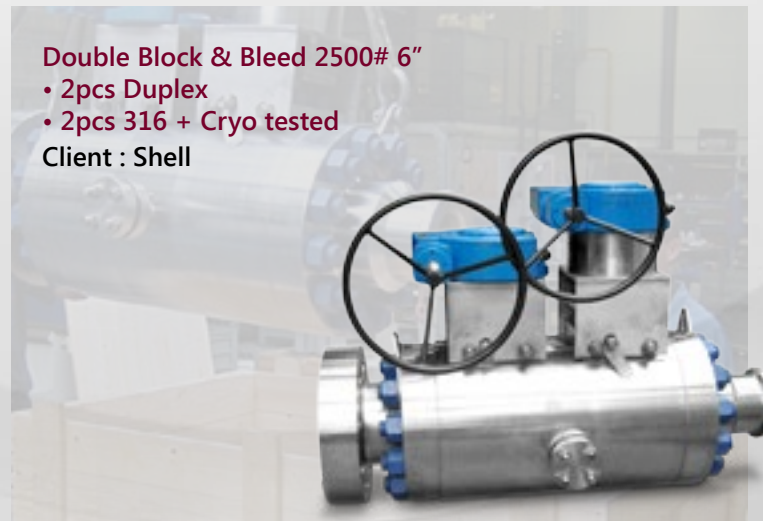

Double Block & Bleed 2500# 6"
 • 2pcs Duplex
 • 2pcs 316 + Cryo tested
 Client : Shell

COMPACT FLANGES

Benefits

Main benefits of L-005 compact flange compared to ASME flange :

- Much **lighter** (save up to 80% on weight)
- **Smaller dimensions** (in both overall length and diameter)
- **More reliable** sealing : Seal ring instead of gaskets
- Multiple sealing areas
- No corrosion/erosion on flange faces (gapless)
- No need to re-tighten bolts on a regular time scale

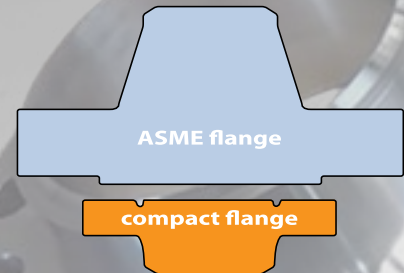

Advantages of a seal ring compared to a standard gasket

- Stronger
- Reusable
- More reliable
- Less maintenance

The Raised Face (RF) on an ASME flange is a weak point

- 1) Bending forces on the piping system will loose bolting on ASME flanges after a while so that re-tightening of the bolts is required. It has NO impact on the compact flange.
- 2) Gap between 2 ASME flanges (caused by RF) can cause corrosion or erosion.

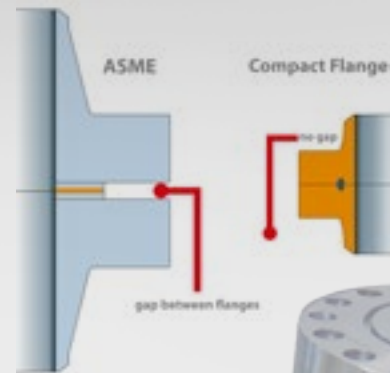

Size benefits

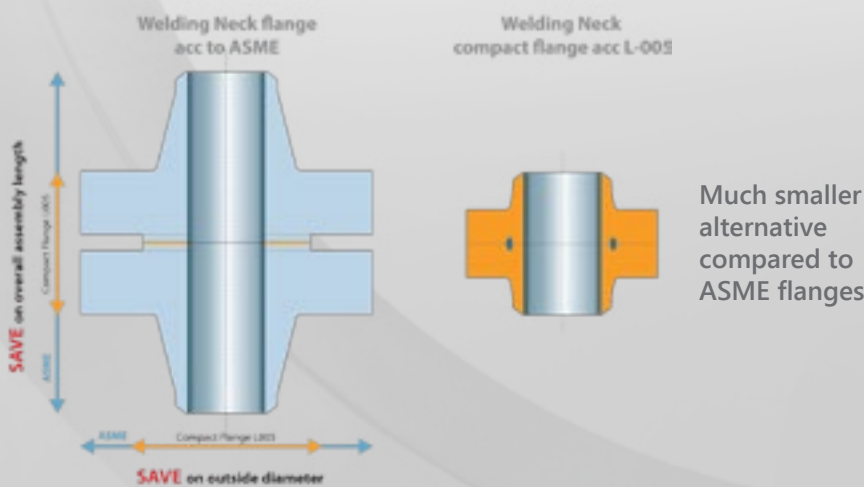

Compact size is ideal for applications with space restrictions like f.ex. **Offshore** rigs and misc. **Subsea** installations like f.ex. X-mas trees.

Weight benefits

78% weight saving!
Weight Comparison WN 2500lbs 10"



FACT : in some cases the weight of 1 ANSI flange = 4-5 compact flanges

Machining



Inhouse machining of CF swivel ring
Block 17 Phase 2
Total Angola



Inhouse machining swivel hubs
Tailor made design based on Norsok L-005



Hydrotest on CF assembly
Block 17 phase 2 Total Angola

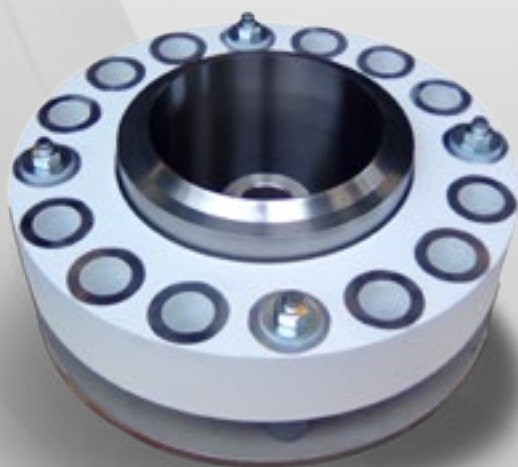

Swivel hub & ring with special coating and flange face protection

Welding Neck CF with proper protection on flange faces



TAILOR-MADE FORGINGS

Product manufacturing range

All sizes from ½" up to 24" (OD run) and larger
Up to 36" on request
Maximum length up to 3500mm

- Buckle Arrestors
- Pipe Anchors
- Hanger Flanges
- Tees and barred tees
- Wyes
- Flanges API6A/B – MSS SP44 – ASME B16.5
- Compact flanges Norsok L005

Integrated forge & foundry

- France based forgemaster (Allonnes)
- Metal forgings from 0,1 kilo to 40 kilos
- Metal castings from 0,1 kilo to 500 kilos
- High strength carbon steels, stainless steel forgings, including duplex and super stainless steel, nickel alloy, copper alloy and titanium alloy forgings



Our partners companies - Partners forge masters working on SCI design and drawings :



Key features :

- UK based forgemaster (Sheffield)
- Metal forgings from 1 kilo to 1200 kilos (maximum outside diameter 1050mm)
- High strength carbon steels, stainless steel forgings, including duplex and super stainless steel, nickel alloy, copper alloy and titanium alloy forgings
- Forging types : boss forgings, forged blocks, forged rings, precision forged, bars and shaped forgings



t.gainza,s.l.

Key features :

- Spanish based forgemaster (Zestoa near Bilbao)
- Three free forgings presses, with a maximum capacity of 5.000 Tons
- Forgings and machining of parts up to 40 Tons
- Disc : maximum diameter is 3.500 mm (40.000 kg)
Rings : maximum diameter is 4.500 mm (10.000 kg)
- Specialized in high pressure forgings and complex pieces as well as many types of deepwater connections

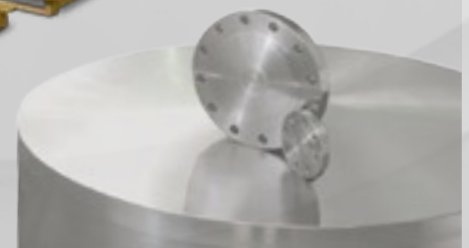
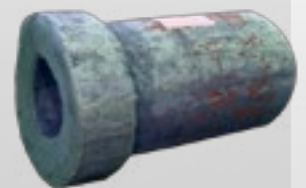



Offshore and subsea products

SCI, ideal partner :

- Broad experience in manufacturing tailor made products for subsea applications
- Already serving the offshore industry for more than 25 years
- Experienced engineering team focused on conception, development and design
- In house elaboration of finite element analysis
- Broad network for forged base-material (European quality)
- Partnership with reliable industry recognized forge masters
- Advanced machine shop with state-of the art machinery
- In house NDT controller and projects dedicated quality control team
- Commercial team dedicated to critical documentation handling and general follow up, one project manager in charge per project covering all steps

ENGINEERING

Customized tailor-made products and solutions

- Experienced engineering team
- Most advanced modelling & simulation software
 - FEA : ■ Samcef field
 - PTC ProMechanica
 - CAD : ■ Autodesk Inventor
 - Autodesk Autocad
 - PTC Pro Engineer
 - CAM : ■ Mastercam
 - Calculation : ■ PTC Mathcad



Our Services

- design and manufacture tailor-made products
- 3D modelling services
- FEA Analysis
- calculations
- reverse engineering services



FEA ANALYSIS

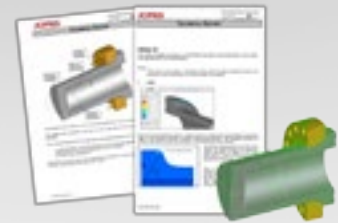

DETAILED CALCULATION REPORT

Design

Long welding neck self reinforced

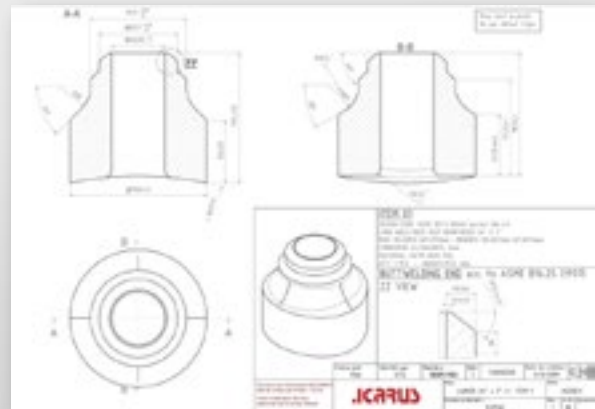
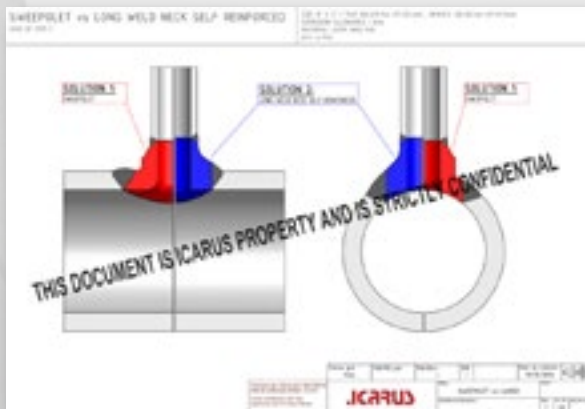

Wyes

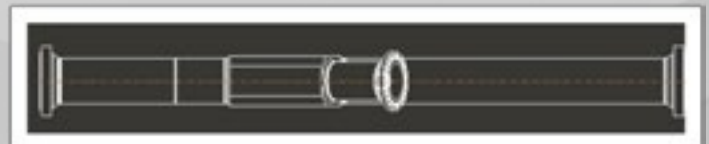

Calculation note

Compact Flange



Swivel Ring CF L-005
Client : Saipem for Total Pazflor project

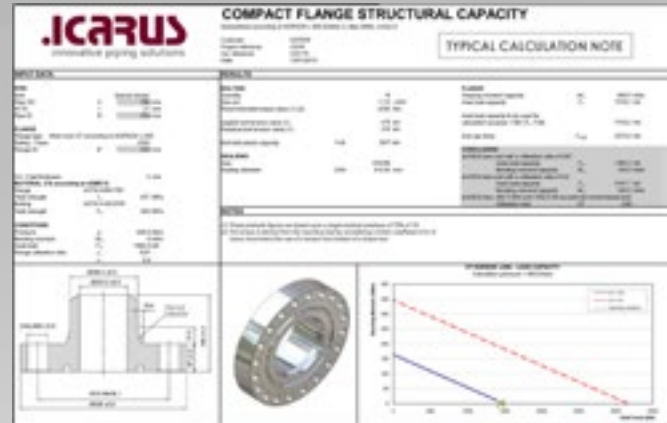

Welding Neck CF 10"
Client : Saipem for Total Pazflor project

Inhouse FEA calculation

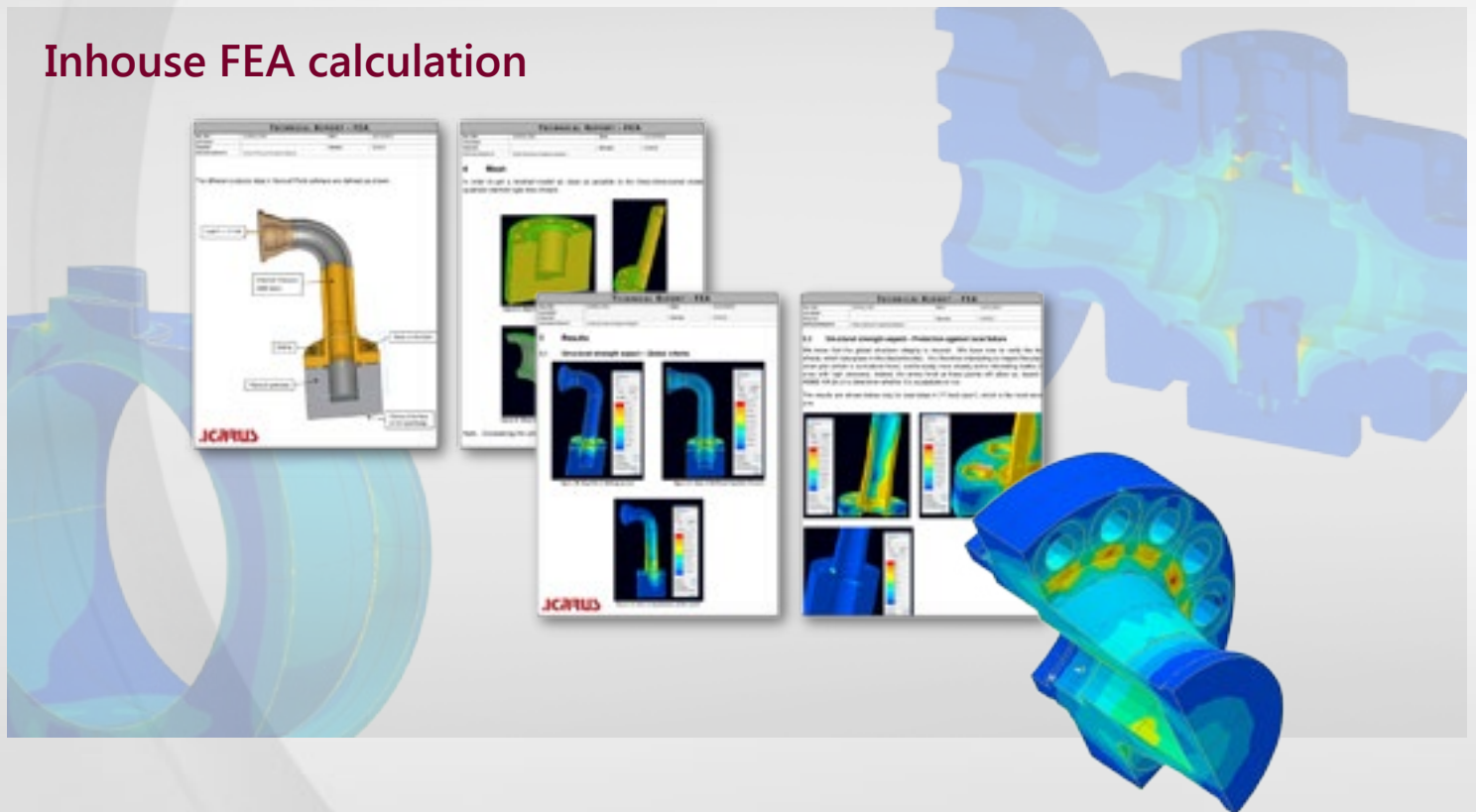

Examples of tailor made projects

- Special compact flanged joint design (based on NORSOK L-005) : including swivel ring flanges, out of standard welding neck flanges, development of special connections for cryogenic applications
- Special flanged joint design (based on ASME B16.5 or API 6A / 17D) : swivel ring flanges.
- Calculation of branch outlet : "Common" solutions as weldolet, design of special branch outlet called the Long Weld Neck Self Reinforced.
- Development of all kind of pressure related equipment.

QUALITY

Dedicated team of QM/QC

- visual and dimensional control of incoming goods
- follow up of specific order/client requirements (marking, extra testing,...)
- on-site inspections of manufacturers plant
- expediting function
- certificates

Dimensional analysis

Specific measuring tools

- FARO 3D Arm
- Wenzel 3D Table
- Coating thickness

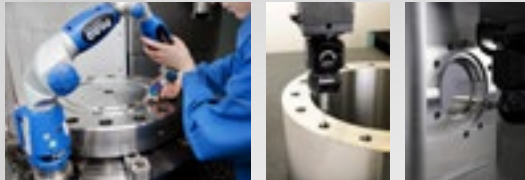

Test range

Non-Destructive tests

- Magnetic test
- Dye Penetrant test
- PMI
- Ferritoscope

Destructive tests

- Hardness



Extreme conditions simulation

Specific environmental or service

- High pressure (air / gas / water)
- Fugitive emission test
- Cryogenic test
- Fire test



Quality management

Professional management of your orders :

- according to our certified Quality System EN ISO 9001/2008
- conforming to the requirements of the European Directive PED 97/23/EC



MACHINERY LIST

Machining Devices

Milling Machines

Brand	Model	Capacity (in mm)
DMG	DMF260	X 2600 / Y 1100 / Z 900 5th axis : Integrated table Ø1050 & Swivel head (axis B) - Power : 52 kW
CME	BF400	X 2500 / Y 1200 / Z 1500 4th axis Ø 600 Automatic head (axis C and axis D indexable 1°) - Power : 23 KW
MAZAK	VTC-200B	X 900 / Y 500 / Z 500 Power : 11 KW
MAXIMART	Q-15	X 1520 / Y 800 / Z 700 Power : 20 KW



Turning Machines

Brand	Model	Capacity (in mm)
SCHIESS	12 DS	Ø 1000 x 600 (Type : Vertical)
DOOSAN	PUMA VT900	Ø 900 x 850 (Type : Vertical)
GEMINIS	CNC 5 plus	Ø 800 x 3000
DEAWOO	PUMA 700M	Ø 800 x 2000
URSUS	plus 300	Ø 400 x 2000
DEAWOO	PUMA 400	Ø 400 x 1500
DEAWOO	PUMA 400L	Ø 400 x 2500



EDM Electrical Discharge Cutting Machine

Brand	Model	Capacity (in mm)
ONA	RE 400	600 x 300 x 400

Saw

Brand	Model	Capacity (in mm)
KASTO	HBA	Horizontal Saw Max Height : 720mm
PEHAKA	HS 540	Horizontal Saw Max Height : 540mm



Welding Post

Brand	Model	Capacity (in mm)
TIG MIGATRONIC	BDH 320	maximum 320 A DC

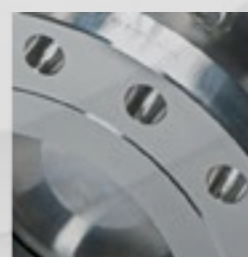
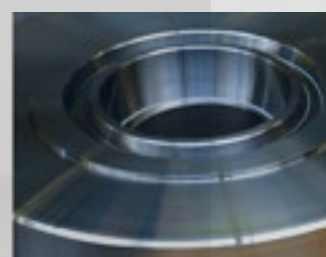

Pressure testing facilities

Test capacities :

- Hydraulic up to 1100 bars
- Pneumatic up to 6 bars
- High Pressure Gas up to 700 bars
- Cryogenic : from ambient to -196°C
- Low fugitive emission test

Test Equipment :

■ Press :

- 15 T (2" 600# → 4" 300#)
- 50 T (6" 600# → 10" 300#)
- 200 T (4" 2500# → 10" 900#)
- 600 T (8" 2500# → 24" 600#)

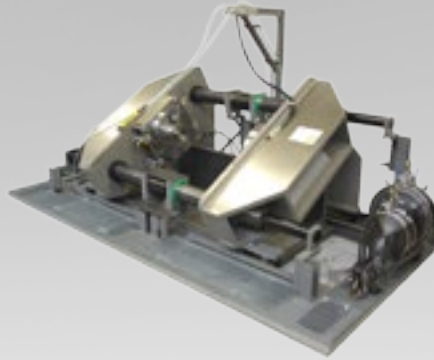

■ Bunker for gas testing for safety purposes



■ Cryogenic tanks

- 2100 x 1000 x 1300 suitable from 20" 900# to 12" 2500#
- 1100 x 600 x 600 suitable for smaller valve (for example : 8" 600#)



■ Pressure test of any special component, or assembly, with caps, blind flanges or specifically designed plugs.



Leak measurement devices :

- Sniffer
- Flow meter
- Bubble counter

Other :

Data recording device

REFERENCES

Frame agreement

Frame agreements with Statoil, AkerSolutions and Total (Congo)

For pipes, flanges, fittings and related equipment in carbon steel, stainless steel & alloy steel.
All sizes and dimensions.



Statoil



TOTAL

Various projects

ENGINEERING	YEAR	DESCRIPTION	QTY	DESTINATION
Technip France	2014	Pipes and flanges API5L gr. B, HSCS Final client : Total Congo – Moho project	150 T	Congo
Foster Wheeler	2014	Pipes flanges and fittings in CS and WP5 Final client : CORAF Congo	250 T	Congo
Technip Qatar	2014	Rings in 24" and 30" in ss 347H – Final client : ORYX GTL	40 T	Qatar
KT Roma	2014	Pipes, flanges and fittings in CS and SS – Final client : Daura	190 T	Irak
HHI	2013	Bends in duplex and CS – Final client : Clair Ridge - BP	99 T	United Kingdom
TSLNG/ SENER-TECHNINT	2013	Pipes flanges & fittings in 304L and CS Final client : ZEEBRUGGE LNG PROJECT - FLUXYS	450 T	Belgium
Saipem	2013	Anchor pieces and flanges in ASTM A694 F65 Final client : Ivar Aasen	15 T	Norway
DSME	2013	Carbon steel AIP5L gr. X65 Final client : Mafumeira Chevron	77 T	Angola
DSME	2013	Bends in HSCS API5L gr. X60 Final client : Mafumeira Chevron	58 T	Angola
Technip France	2013	Smls pipes in CS/HSCS/Stainless steel, duplex Final client : Total Angola	95 T	Angola
Saipem Italy	2013	Smls pipes in CS GrB / Gr 6 Final client : Chevron Mafumeira Pjt	150T	Congo/Angola
Petroineos	2013	Piping package in 317L – Final client : Petroineos	90T	France
SBM	2013	Duplex and super duplex flanges and piping Final client : Inpex/Total Ychtis Project	100T	Norway
KT Roma	2013	Pipes flanges manifolds & fittings in 347H, 304H, CS and alloy steel – Final client : Aramco / Samsung	250T	Saudi Arabia
KT Roma	2013	Pipes flanges and fittings in CS and alloy steel Final client : Lukoil - Progetto PERM	300T	Russia
HHI	2013	Bends duplex - HSCS Final client : BP - Clair Ridge - Scotland	45T	Korea
Mc Dermott	2013	Stainless steel - alloy 625 – Final client : Aramco - Karan	10T	Dubai

ENGINEERING	YEAR	DESCRIPTION	QTY	DESTINATION
Mc Dermott	2013	Duplex - 6mo – Final client : Aramco - KJO	16T	Dubai
HHI	2013	CS + HSCS bends – Final client : DSO - Chevron	12 T	Korea
Air liquide	2013	BGLA carbon steel fittings – Final client : Jabekke Aquafin	1 T	Belgium
Air liquide	2013	BGLA carbon steel pipes and fittings Final client : Tessenderlo Antenna	5 T	Belgium
DSME	2012	HSCS bends and duplex bends Final client : Wheatstone project / Chevron	95 T	Korea
Technip Norway	2012	Compact flanges F65 - duplex - super duplex Final client : Marathon oil	50 T	Norway
Technip Italy	2012	Pipes in A335 GR P22 – Final client : BRASKEM	300 T	Messico
Saipem France	2012	Buckle arrestors - pipe anchors – Final client : Bonga Shell	45 T	Nigeria
Subsea 7	2012	API 6 A - MSS SP44 cladded flanges F65 Final client : Total Nigeria - CLOV	32 T	Nigeria
TKT Roma- Technip Roma	2012	Manifolds in 347H & Alloy 800H Final client : ORYX GTL/SASOL	400 T	Qatar
HHI	2012	Seamless pipes superduplex – Final client : Clair Ridge	128 T	Korea
SBM	2012	QUAD Pjt pipes, bends, flanges fittings, barred Tee in duplex and super duplex – Final client : SBM	600 T	Norway
SBM	2012	OSX Project flanges in F52-F65 – Final client : SBM	10 T	Brasil
DSME	2012	Duplex tee extension - cladded with stellite gr. 6 Final client : Wheatstone project / Chevron	15 T	Korea
DSME	2012	3 way + globe valves – Final client : SNX project	1 T	Korea
DSME	2012	API5L gr. X65 pipes – Final client : Wheatstone project	56 T	Korea
Foster Wheeler	2012	Fittings + pipes + flanges in staniless + carbon steel Final client : Storeny GRT Gaz	150 T	Beynes France
Technip Iberia	2111	CS + Stainless steel piping Final client : Adisseo Espagne Pjt Europe 2	340 T	Spain
Foster Wheeler	2012	CS, SS, AS pipes flanges and fittings Final client : Total Petrochemical	150 T	France
HHI	2012	Welded duplex bends – Final client : Goliath - Eni Norge	20 T	Korea
HHI	2012	Seamless pipes duplex – Final client : QUAD 204 FPSO	35 T	Korea
HHI	2012	Seamless pipes alloy 625 – Final client : QUAD 204 FPSO	11 T	Korea
Tractebel	2012	Fittings + pipes + flanges in staniless + carbon steel Final client : FLUXYS - BELGIUM	15 T	Belgium
BASF AG	2011	Various packages of pipes - fittings - flanges - plates - bars in 2.4602 / alloy C22 and alloy 800H for maintenance purposes Final client : BASF LUDWIGSHAFEN	8,5 T	Germany
Petroplus Deutschland GMBH	2011	SHUT-DOWN 2011 - various piping materials in 2.4856 / alloy 625, 2.4858 / alloy 825, F11 and 1.4541 / 321 material Final client : PETROPLUS RAFFINERIE INGOLSTADT	2,5 T	Germany
Tecnimont Roma	2011	P22 - 347 H & 321 piping – Final client : HYL TENOVA	350 T	Italy
GE Italy	2011	Pipes fittings & Flanges in duplex and super Duplex Final client : ZENON EUROPE MANUFACTURING	150 T	Hungary
Tecnimont Roma	2011	Piping in CS and stainless steel Final client : ARAMCO - JUBAIL PROJECT	350 T	Saudi Arabia

ENGINEERING	YEAR	DESCRIPTION	QTY	DESTINATION
Saipem Italy	2011	Alloy 825, Stainless 316, Carbon steel pipes, flanges and fittings – Final client : KASHAGAN PROJECT	200 T	Kazakhstan
Technip Italy	2011	Nickel alloy, low alloy and stainless steel pipes, fittings and flanges – Final client : ARAMCO - JUBAIL PROJECT	50 T	Saudi Arabia
JGC	2011	WPQT pipes stainless steel welded pipes Final client : BARZAN - Ras Gas	14 T	Japan
HHI	2011	WPQT pipes alloy 825 – Final client : BARZAN - Ras Gas	5 T	Korea
JGC	2011	Plates 6Mo - Sduplex - Duplex - alloy 825 - alloy 625 Final client : BARZAN - Ras Gas	15 T	Japan
HHI	2011	Fittings BW + forged fittings alloy 825 Final client : BARZAN - Ras Gas	25 T	Korea
HHI	2011	Seamless pipes alloy 825 – Final client : BARZAN - Ras Gas	35 T	Korea
HHI	2011	Valves in AP6A 5000 carbon steel (50pces) 2 1/16" and 3 1/8" - cs ss 6Mo ASME/API6D (1400 pces) 1/2" up to 8" cl 150 to 2500 Final client : BARZAN - Ras Gas	50 T	Korea
HHI	2011	Valves in API6Apsl2 5000 alloy 625 - 2 1/16" -3" 1/8 - 4 1/16" and ASME/API6D from 1/2" up to 4" cl 150 to 2500 alloy 825 (90pces API + 1065pces ASTM) Final client : BARZAN - Ras Gas	60 T	Korea
Igawara	2011	Alloy 825 pipes – Final client : ONGC	15 T	Malaysia
Hitachi Zosen	2011	Duplex pipes - stainless steel pipes – Final client : TAKREER	50 T	Abu Dhabi
Polysindo	2011	Pipe - fitting stainless steel – Final client : POLYSINDO	8 T	Indonesia
Saipem Singapore	2011	HSCS pipes and fittings – Final client : LIWAN submarine	10 T	China
Samsung Engineering	2011	Carbon steel pipes - alloy pipes Final client : SKIKDA REFINERY - ALGERIA	25 T	Algeria
Samsung Engineering	2011	SMLS Pipes in API5L gr. X65 Final client : PETRONAS - SOGT	1000 T	Malaysia
Samsung Engineering	2011	SMLS Pipes in CS GrB / Gr 6 Final client : PETRONAS - SOGT	3000 T	Malaysia
Hitachi Zosen	2011	Duplex Pipe / Fittings – Final client : ADNOC - Takreer	30 T	Abu Dhabi
SBM Malaysia	2011	Valves in Cupro nickel (globe & gate) Final client : ASENG Project - Benita (Malaysia)	150 T	Guinea
Akzo Nobel China	2011	SPO Compact Flanges / SPO Paddle Spacers & Blanks in 316L Final client : AKZO NOBEL - SITE IN CHINA	2 T	China
JGC Yokohama	2011	Plates in Alloy 825 and Grade 1 Final client : GASCO - Habshan	56 T	UAE
Bluewater Energy Services	2011	Hub/Clamp Techlok Connectors in carbon and stainless steel for a shortage on site Final client : ENI AUSTRALIA - KITAN FIELD DEVELOPMENT	2,5 T	Australia
Jacobs	2011	Montoir pipes fittings and flanges in stainless steel Final client : GDF Suez	1 T	France
Ineos Geel/Tractebel	2011	BGLA pipes fittings and flanges in carbon steel Final client : Ineos Geel	8 T	Belgium
NPCC/SNTC /Tractebel	2011	BGLA pipes fittings and flanges in stainless steel and carbon steel – Final client : AGT Ineos Feluy	16 T	Belgium
Total Refinery Antwerp	2011	Tubing in Titanium Gr. 2 Final client : TOTAL ANTWERP REFINERY SITE	0,8 T	Belgium

ENGINEERING	YEAR	DESCRIPTION	QTY	DESTINATION
BASF Anrwerp	2011	Various packages of pipes - fittings - flanges - bars in 16Mo3, 321H, 2.4602 / alloy C22 and 1.4876 Final client : BASF ANTWERP SITE	5 T	Belgium
FLUXYS SA	2011	Pipes fittings and flanges stainless steel and carbon steel – Final client : FLUXYS - BELGIUM	20 T	Belgium
Technip Lyon	2011	Stainless steel 316 L & 304L piping Final client : Adisseo France Pjt Europe 2	150 T	France
Technip France	2011	F65 compact flanges – Final client : Girri Project - Total	1 T	Nigeria
Technip France	2011	SS welded pipe – Final client : PMP QATAR GAS	200 T	France
Foster Wheeler	2011	CS + Alloy steel and SS steel piping Final client : Ineos - Pjt les Amines	170 T	France
Sofresid Aix	2011	Smls Pipe and bends in X52 + PE cotated Final client : TOTAL RAFFINERIE DE NORMANDIE - UGO Pjt	40 T	France
Technip France (Lyon)	2011	Stainless and CS piping Final client : GDF SUEZ - STORENGY	25 T	Tersanne France
Technip France (Paris)	2011	Welded stainless steel pipes Final client : PMP QATAR GAS	200T	Qatar
Ineos Lavera	2011	Alloy and stailless steel pipes Final client : INEOS LAVERA - Convection B301	50 T	Lavera France
Sofresid Aix	2011	BW Fittings in WPHY in X65 Final client : TOTAL RAFFINERIE DE NORMANDIE	5 T	France
GDF Suez E&P	2011	3-Way Ball valves in low-temp carbon steel of 12" x 150 LBS and 18" x 150 LBS – Final client : GDF SUEZ E&P	14,5 T	The Netherlands
Alstom power GMBH	2011	Smls tubes in alloy 625 material Final client : ALSTOM POWER SYSTEMS GMBH	1,5 T	Germany
Lehner AG Maschinenfabrik	2011	Package of pipes - fittings - flanges in low-temp carbon steel and stainless steel Final client : MAN DIESEL & TURBO SCHWEIZ	15 T	Switzerland
Kirsch Apparate GMBH	2011	Welded tubes in 2.4605 / alloy 59 for replacement apparatus construction – Final client : BASF LUDWIGSHAFEN	1,5 T	Germany
Alexander Wiegand GMBH	2011	Various bars in carbon - chrome-molybdenum - stainless steel - superduplex and nickel alloy materials Final client : ALEXANDER WIEGAND GMBH	19 T	Germany
Saipem	2011	Duplex and HSCS fittings – Final client : Kizomba - Exxon	5 T	Angola
SBM Monaco	2011	Compcat Flanges in Duplex and CS Final client : BALEIA AZUL	70 T	Brazil
SBM Monaco	2011	CS & SS piping – Final client : TOTAL Congo	50 T	Congo
Lurgi Polska SA	2011	Piping material in carbon steel / P5 / 316LMO+ – Final client : CDU/VDU UNIT FOR LOTOS GDANSK REFINERY PROJECT	35 T	Poland
Lukoil -Permnefteorgsintez	2011	HYDRA SPRING HANGERS Final client : LUKOIL-PERMNEFTEORGSIINTEZ REFINERY	3,5 T	Russia
Tecnicas Reunidas	2011	Duplex and super duplex piping – Final client : RTARAGONA	90 T	Spain
Technip Iberia	2011	Stainless in 321 & Carbon steel piping Final client : INEOS LAVERA - HCK Reactor	120 T	Lavera France
Alexander Wiegand GMBH	2011	Various plates and bars in stainless steel and nickel alloy materials – Final client : ALEXANDER WIEGAND GMBH	3,5 T	Germany
Hyundai Heavy Industries	2010	Stainless steel tubing	5T	Korea



Tel: 081-68866016
21, Boyle Street (2nd Floor)
Onikan - Lagos

Tel: 070-46082992
32, Emekuku Street
Port Harcourt

EUROPEAN OFFICES :

SACCAP

112, Avenue de Vendôme
41034 Blois
France

COYARD

1, Rue de la Nouette
49072 Beaucouzé Cedex
France

ICARUS

Rue des Alouettes, 100
4040 Herstal
Belgique



www.sci-ng.com